



Product Recovery Systems

Increase product yields and reduce CIP costs

Features

- Easily integrates into existing systems
- Simple to operate
- Safe and secure
- Controls included
- Pig detection and air control systems
- Built-in pressure release for operator safety

Benefits

- Increase product yield by recovering usable product
- Decrease CIP cleaning time
- Reduce water and chemical usage
- Lower waste treatment expenses

Product Recovery Systems

Basic Control Package

- Stand-alone system
- Designed for one-way recovery
- Built-in velocity control for projectile
- NEMA 4X rated
- Stainless steel construction

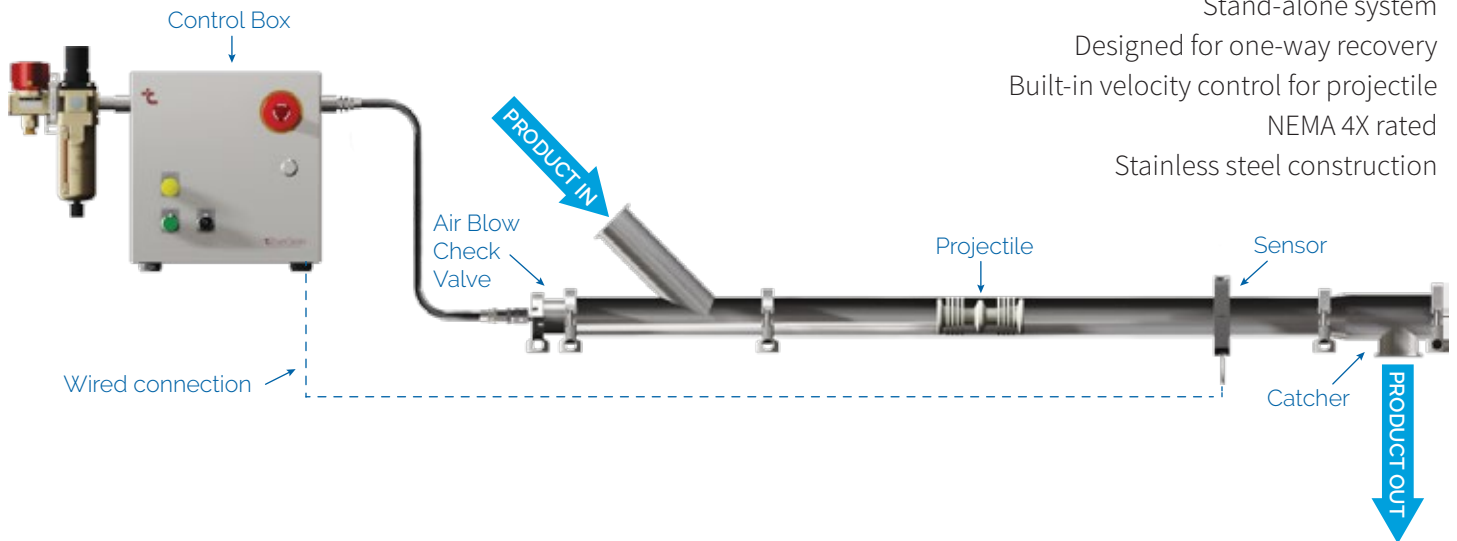

Automated Return Package

- Ideal for difficult-to-reach or distant catch locations
- Built-in velocity control for projectile
- NEMA 4X rated
- Stainless steel construction
- PLC interlocks available

